

DuoScan HiD

Owner's Guide



[Preface](#)

This chapter gives you general information about DuoScan HiD.

[Chapter 1 — Preparing the scanner](#)

This chapter shows you how to prepare your DuoScan HiD for installation.

[Chapter 2 — Installing the scanner](#)

This chapter shows you how to set up your DuoScan HiD for the Apple Macintosh and PC.

[Appendix A — Troubleshooting](#)

This appendix can be helpful when you come across problems that you are unable to solve.

[Appendix B — Technical information](#)

This appendix provides specifications of your DuoScan HiD.

[Appendix C — DuoScan HiD regulation compliance](#)

This appendix gives you information on the safety regulations and on electromagnetic interference.

Trademarks

Agfa and the Agfa rhombus are trademarks of Agfa-Gevaert AG.

DuoScan HiD, ColorTune and FotoLook are trademarks of Agfa-Gevaert N.V.

Adaptec is a trademark of Adaptec.

Adobe Acrobat and the Acrobat logo are trademarks of Adobe Systems, Incorporated.

Intel is a registered trademark of Intel Corporation

Power Macintosh and System 8 are trademarks and Apple and Macintosh are registered trademarks of Apple Computer, Incorporated.

Windows, Windows NT and the Windows logo are trademarks or registered trademarks of Microsoft Corporation.

Other products or company names are trademarks or registered trademarks of their respective holders.

Copyright © 1999 Agfa-Gevaert N.V.

All rights reserved.

All software and hardware described in this document is subject to change without notice.

Contents

Preface	5
Chapter 1 — Preparing the scanner	6
Unpacking the scanner	7
Unlocking the scanner	7
Relocking the scanner	8
Taking a closer look	9
Placing reflective originals	12
Placing transparent originals	12
Using the universal glass frame	13
Using the regular slide holders	13
Using batch slide holders	15
35 mm framed batch slide holder	15
35 mm strip batch slide holder	16
6 x 9 cm batch slide holder / 4 x 5 inch batch slide holder	17
Performing a power-on test	19
Chapter 2 — Installing the scanner	20
Minimum hardware requirements and recommendations	21
Environmental requirements	22
Precautions	22
Cleaning your scanner	23
SCSI devices	23
Installation for the Apple Macintosh	24
Which SCSI interface card	24
Choosing a SCSI ID number	24
Connecting the scanner	26
Testing the connection	30
Installation for the PC	31
Which SCSI interface card	31
Choosing a SCSI ID number	31
Connecting the scanner	33
Testing the connection	37

Appendix A — Troubleshooting	38
Appendix B — Technical Information	40
Appendix C — Regulation Compliance	42
Safety regulations	42
UL Safety Statement	42
FTZ: Bescheinigung des Herstellers/Importeurs	42
TÜV: Wichtige Sicherheitshinweise	42
Electromagnetic interference	43
Federal Communications Commission Radio Frequency Interference Statement.....	43
Canadian department of Communications	44

Preface

DuoScan HiD is a high-resolution scanner that scans reflective and transparent originals, each on an independent scan bed. The transparent scan area is a revolutionary innovation because of the Twinplate™ scanning system. This allows you to scan without glass plates distorting the optical path. Instead of only switching the light source, the scanner switches mirrors and thereby uses a different optical path to scan transparent originals. This allows the scanner to optimize the optical path for both types of originals.

DuoScan HiD's image quality makes it perfectly suitable for pre-press graphical applications. It is based on flatbed CCD (Charge Coupled Device) scanning technology. DuoScan HiD is characterized by a large input size range and a high scanning speed. Thanks to its 8,000 CCD pixels, an impressive output size range can be achieved. This high-precision instrument features exceptional sharpness and color fidelity.

The universal glass frame, the slide holder frame and the batch slide holders allow you to scan transparent originals without using the reflective glass plate. Three regular slide holders are supplied with DuoScan HiD, together with several types of batch slide holders which are available as an option in order to increase the productivity of the scanner. The document cover is adjustable for reflective scanning: when you put a thicker original (like a book or a magazine) on the reflective glass plate, the document cover adapts itself to its thickness.

The originals can be of any type. The FotoLook scanning software will optimize the scan result. The features of ColorTune and FotoFlavor software make it possible to create an output in compliance with your personal wishes (realistic colors, special color effects,...). The bit depths can be either 3 x 14 bit for color (packed into 3 x 16 bit or truncated to 3 x 8 bit), 14 bit for gray scale originals, or 1 bit for line-art originals. The scanned data are transferred to the workstation through SCSI-2. The workstation can be either an Apple® Macintosh® or PC®.

Chapter 1 — Preparing the scanner



This chapter assists you in preparing your DuoScan HiD for installation. You will find instructions for:

[Unpacking the scanner](#)

[Unlocking the scanner](#)

[Relocking the scanner](#)

[Taking a closer look](#)

[Placing reflective originals](#)

[Placing transparent originals](#)

[Using the universal glass frame](#)

[Using the regular slide holders](#)

[Using batch slide holders](#)

[35 mm framed batch slide holder](#)

[35 mm strip batch slide holder](#)

[6x9cm or 4x5inch batch slide holder](#)

[Performing a power-on test](#)

Unpacking the scanner

1. Open the packing box and carefully take out all the items.
2. Check each item to make sure that there is no visual defect.
If something is missing, or damaged, contact your dealer or Agfa service representative.
3. Remove the plastic wrapping and the packing materials from the scanner.
 - ❖ Note: Save the packing materials so that you can repack the scanner to protect it if you have to move it over long distances.
4. Fill out the Warranty and Registration card. You will find the product serial number on it.
 - ❖ Note: Do not forget to mail the Warranty and Registration card. Only then can you claim your guarantee and get information on new products and upgrades.

Unlocking the scanner

The scanner's optical carriage contains all optical components and rides back and forth during the scan. An unlocking screw holds it in place at the right side of the scanner during shipment. You must remove this screw before powering up the scanner.

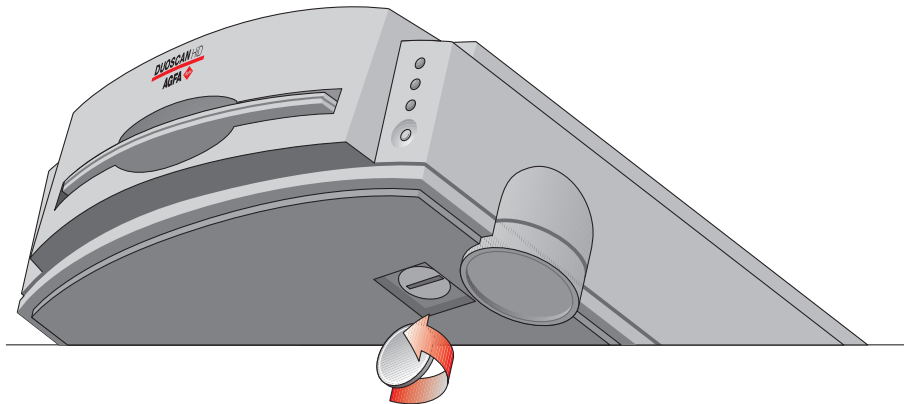

1. Pull the scanner forwards on the edge of the table until you can see the unlocking screw on the bottom of the scanner.
2. Take a coin and turn the screw a quarter counterclockwise.
The screw comes loose: your scanner is unlocked.
3. Move the scanner back on your desktop. Allow a minimum of 10 cm (4 inches) around each side of the scanner and a minimum of 15 cm (6 inches) at the rear side of the scanner.

Relocking the scanner

If you need to transport the scanner, you should relock your scanner. This will protect the scanner's optical assembly from possible damage.

1. Switch your scanner on.
2. Pull the scanner forwards on the edge of the table until you can see the unlocking screw on the bottom of the scanner.
3. Take a coin and turn the screw a quarter clockwise.
The screw is fastened: your scanner is locked.
4. Move the scanner back on your desktop.
5. Turn your scanner off.

Taking a closer look

Now that you have the scanner out of the box, take a closer look so that you become familiar with its parts. This figure illustrates the locations of the different parts of your DuoScan HiD.

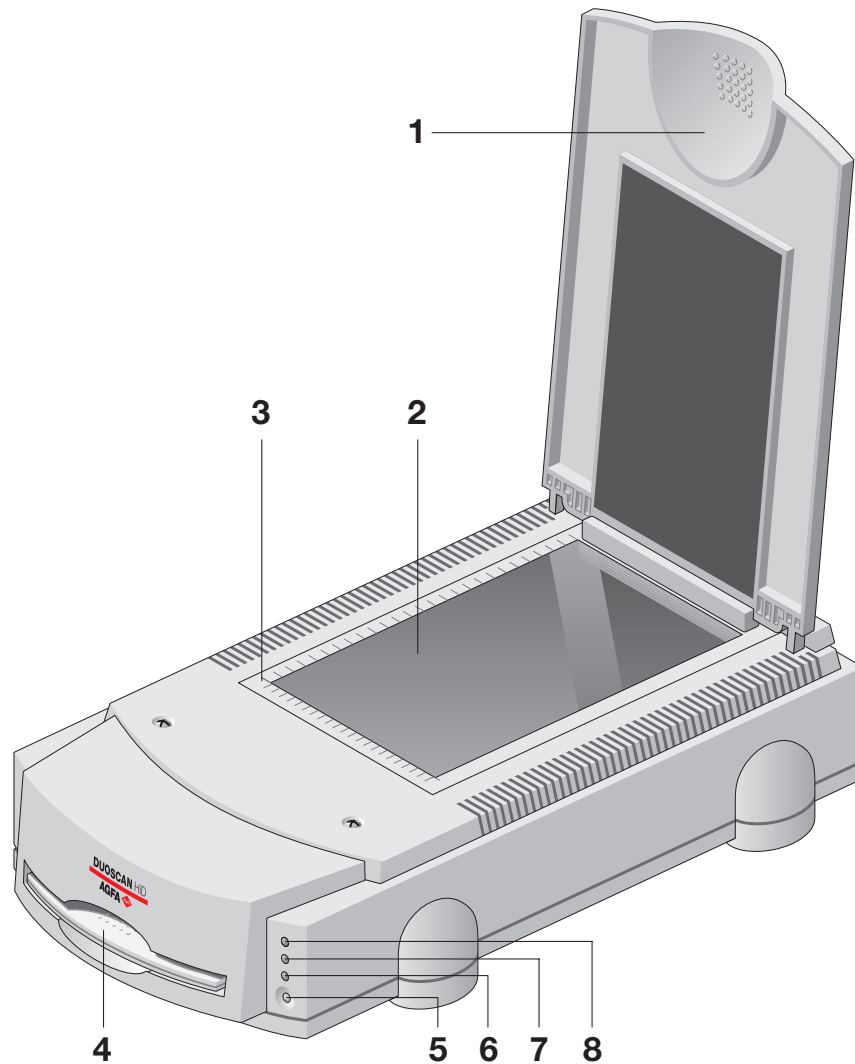

1. adjustable document cover
2. reflective glass plate
3. rulers
4. transparency tray
5. power switch
6. power indicator
7. transparency ready indicator
8. reflective ready indicator

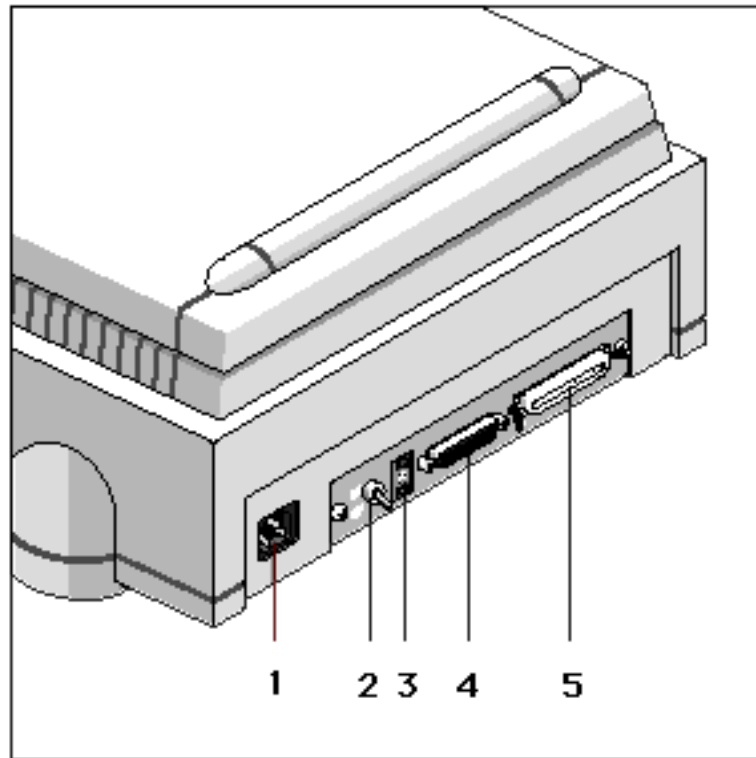

1. power input
2. SCSI terminator switch
3. SCSI ID switch
4. 25-pin connector
5. 50-pin connector

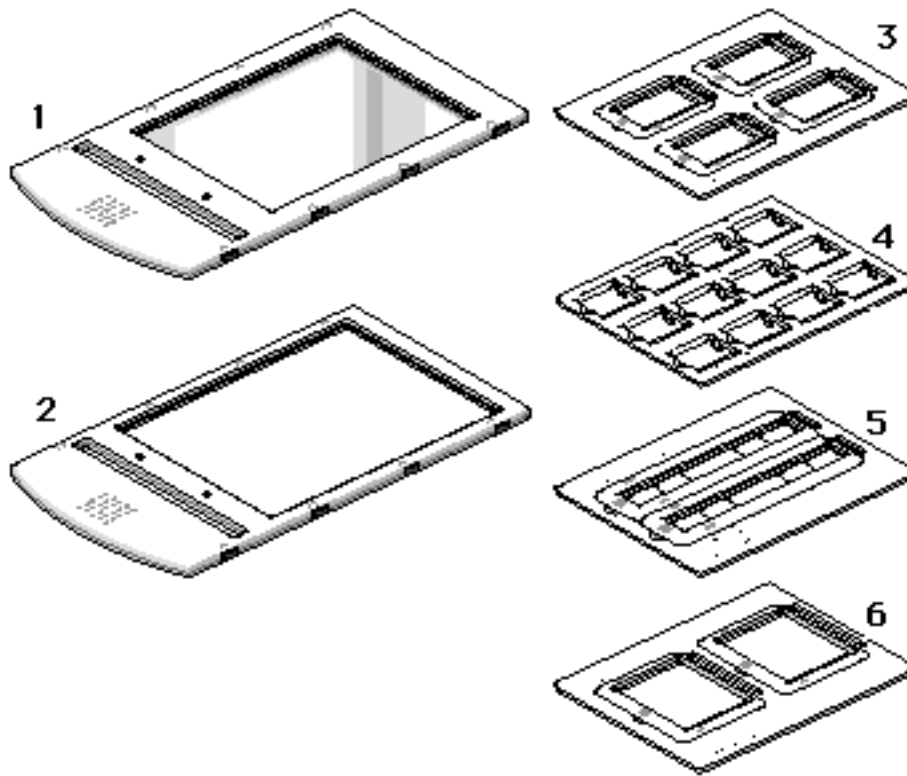

1. Universal glass frame
2. Slide holder frame
3. 6 x 9 cm batch slide holder
4. 35 mm framed batch slide holder
5. 35 mm strip batch slide holder
6. 4 x 5 inch batch slide holder.

Placing reflective originals

You can place a reflective original directly on the scanner's reflective glass plate. A new feature of your DuoScan HiD is the adjustable document cover: when you put a thicker original (like a book or a magazine) on the reflective glass plate, the document cover adapts itself to its thickness.

1. Open the document cover of the scanner.
2. Place the original face down on the reflective glass plate, with its top side against the middle of the front ruler.

The optical performance of a CCD scanner is always best near the middle of the scan area. However, for the most common resolutions used for reflective originals, placing originals to the side will not decrease quality.

3. Close the document cover of the scanner.

Placing transparent originals

When you scan transparent originals, you use either a batch slide holder frame or the universal glass frame.

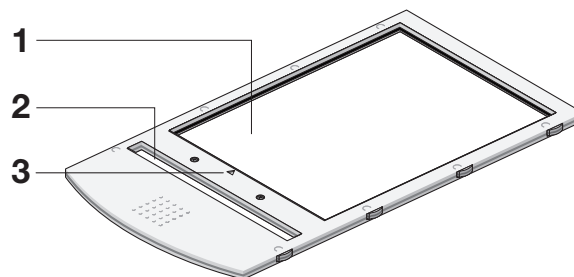

1. universal glass frame
2. calibration slit
3. arrow indicating where to place transparent originals

❖ Note: You find this arrow only on the top-side of the frame.

Caution: You always have to attach your transparent originals to the slide holder frame either with the clips of the universal slide holder, or by using a batch slide holder, or with adhesive tape, even if your transparent originals are fixed in a regular slide holder. Otherwise you might lose them in the scanner.

Using the universal glass frame

To scan a transparent original, carry out the following instructions:

1. Center the original on the universal slide holder so that its top side is directed towards the calibration slit of the slide holder frame when you put the universal slide holder on the slide holder frame of the scanner. The arrow on the frame indicates the position that guarantees the best quality.
 2. Clip your original underneath the edge of the universal slide holder.
 3. Put the slide holder frame into the transparency tray.
- ❖ Note: Make sure that the calibration slit of the slide holder frame is at the front side (standing in front of the scanner) and that it is clean.

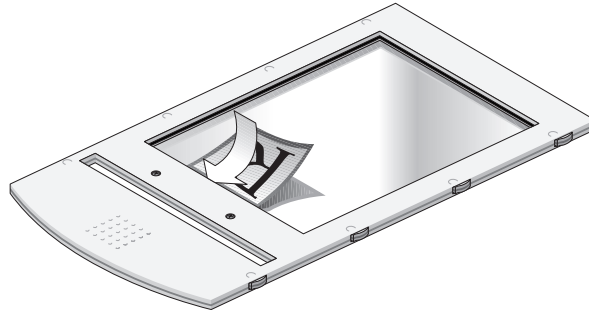

Using the regular slide holders

You can also put your originals in a regular slide holder to avoid blooming and newton rings. There are three types of regular slide holders: 35 mm strip, 6 x 6 cm, and 4 x 5 inch. To scan a transparent original using a regular slide holder, carry out the following instructions:

1. Put your original in a slide holder.
2. Center the original on the universal glass frame so that its top side is directed towards the calibration slit of the slide holder frame. This position guarantees the best quality.
3. Fix the slide holder on the universal glass frame by pushing it firmly down, the rear of the holder having a glass adhesive, thereby securing it to the glass. The holder can still be removed easily.
4. Put the universal glass frame into the transparency tray with the Agfa logo facing upwards.

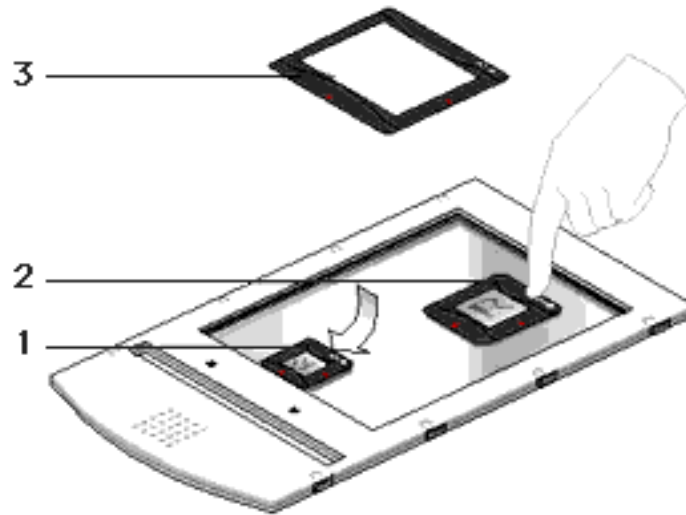

1. 35 mm regular slide holder
2. 6 x 6 cm regular slide holder
3. 4 x 5 inch regular slide holder

The specifications (resolution,...) of the scanner apply to the whole scan area. However, image quality is always at its optimum in the middle of the scan area.

Using batch slide holders

There are three different kinds of batch slide holder that can be used in conjunction with the batch slide holder frame to increase the productivity of the scanner.

35 mm framed batch slide holder

This frame can hold a maximum of twelve premounted slides at any time, once loaded it is mounted into the batch slide holder frame.

Mount a slide into the frame

1. Locate the edge of the slide into the indentation on the arm of the holder.
2. Push the slide down into the aperture.
3. Ensure that the slide is secured by the six fixing lugs on the inside of the frame.

The slide position might need slight adjustment after location.

4. When all the slides have been mounted locate the batch slide holder into the batch slide holder frame.

Remove a slide from the frame

1. Remove the batch slide holder from the batch slide holder frame.
2. Push the slide gently from underneath, releasing the grip of the mounting lugs.
3. Pull away from the indentation.

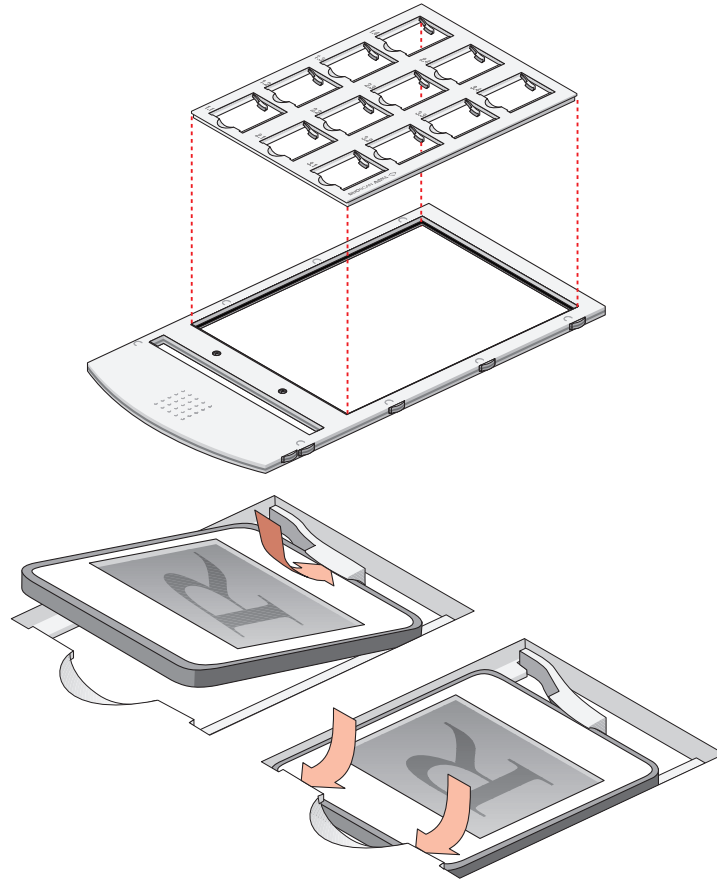

35 mm strip batch slide holder

Two strips of five slides can be mounted into the holder which is then mounted into the batch slide holder frame.

Mount a slide into the frame

1. Unlock the strip slide frame by placing your thumb on the raised points on the end of the holder and pushing the strip slide frame towards the hinge slot. The frame will become loose.
2. Lift the strip slide frame.
3. Place the strip of slides into the centre of the frame.
4. Close the frame.
5. Lock the frame in position by sliding away from the hinge slot. The position of the slides can be readjusted slightly by moving the slides within the holder.

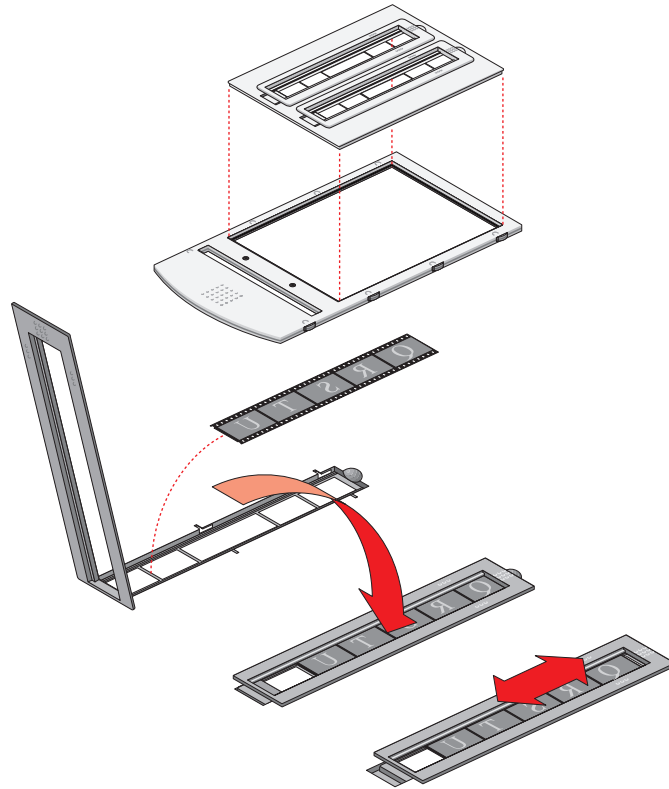

Remove a slide from the frame

1. Unlock the strip slide frame.
2. Lift the strip slide frame.
3. Remove the slide strip.

6 x 9 cm batch slide holder / 4 x 5 inch batch slide holder

These frame holders can hold several slides at a time, once loaded it is mounted into the batch slide holder frame. To mount or remove slides for the 6 x 9 cm and the 4 x 5 inch slide holders you have to apply the same principles.

Mount a slide into the frame

1. Unlock the frame by placing your thumb on the raised points on the end of the holder and pushing the frame towards the hinge slot. The frame will become loose.
2. Lift the frame.
3. Locate the slide against the front edge of the holder.
4. Close the frame.
5. Lock the frame in position by sliding it away from the hinge slot.

Remove a slide from the frame

1. Unlock the frame by placing your thumb on the raised points on the end of the holder and pushing the frame towards the hinge slot. The frame will become loose.
2. Lift the frame.
3. Remove the slide.
4. Close the frame.

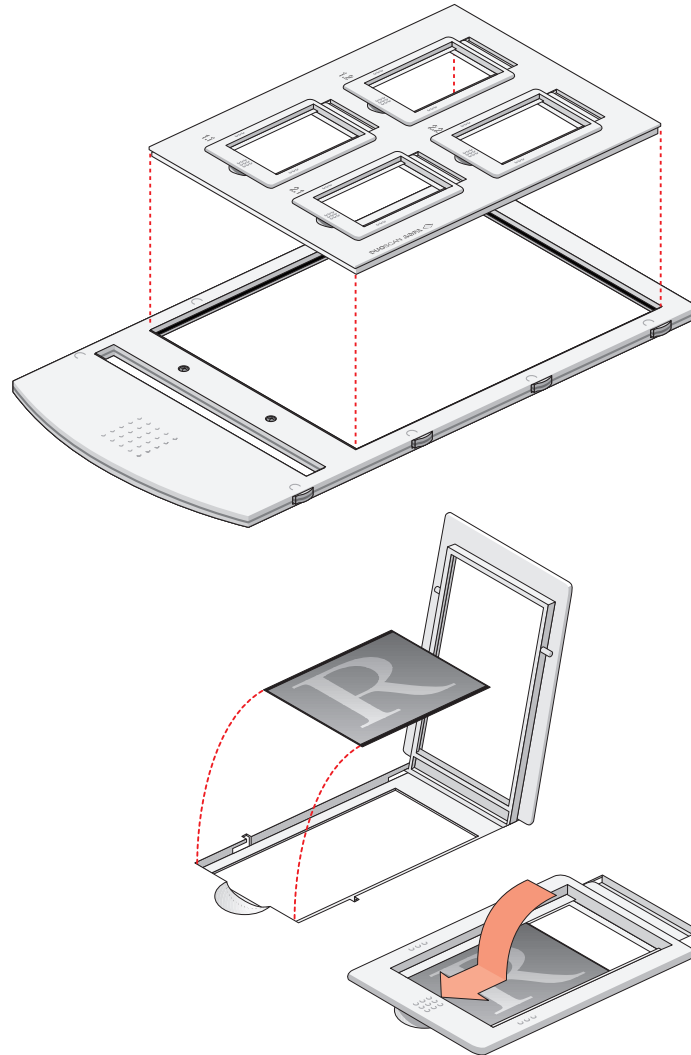

Performing a power-on test

You are now ready to perform a power-on test to check if the scanner is operating correctly.

1. Check whether you have unlocked the scanner.

2. Connect the power cable to the scanner.

Make sure that you are using the correct power cable for the voltage in your area. Double-check whether the voltage indicated on the back panel of the scanner corresponds with the voltage in your area. If not, call your dealer or Agfa service representative.

3. Switch on the scanner.

The scanner performs a self-test during which the power indicator light (green) switches on and the reflective ready indicator light (yellow) and the transparency ready indicator light (yellow) remain blinking. This takes about half a minute. After the self-test the power indicator and the reflective ready indicator light up.

If a malfunction is detected during the self-test, that is, if the ready indicators remain blinking or go off, refer to [Appendix A, 'Troubleshooting'](#).

4. Switch off the scanner.

Chapter 2 — Installing the scanner



This chapter shows you how to set up your DuoScan HiD with your Apple Macintosh or PC. You'll find information about:

[Minimum Hardware requirements and recommendations](#)

[Environmental requirements](#)

[Precautions](#)

[Cleaning your scanner](#)

[SCSI devices](#)

[Installation for the Apple Macintosh](#)

[Which SCSI interface card](#)

[Choosing a SCSI ID number](#)

[Connecting the scanner](#)

[Testing the connection](#)

[Installation for the PC](#)

[Which SCSI interface card](#)

[Choosing a SCSI ID number](#)

[Connecting the scanner](#)

[Testing the connection](#)

Minimum hardware requirements and recommendations

- For the Apple Macintosh:
 - A Power PC Macintosh.
 - 32 MB of RAM.
 - A 17 inch (832 x 624) monitor (with thousands of colors).
 - System 8.
 - 40 MB of free disk space on the start-up disk.
 - A CD-ROM drive.

- For the PC:
 - A pentium processor or higher.
 - A 15 inch color monitor.
 - A video card for an accurate display of color images (minimum thousands of colors).
 - 32 MB of RAM (64 MB of RAM is recommended).
 - FotoLook™ is compatible with all IBM™ PC's and compatibles capable of running Windows 95, Windows 98 or NT 4.0 for Intel platforms.
 - An ASPI compatible SCSI card. In general, FotoLook supports all fully WINASPI compatible cards. Some SCSI cards require a special SCSI cable (e.g. wide SCSI). Contact your supplier for the proper cable.
 - ❖ Note: Please read the installation and set-up guidelines in the documentation that is supplied together with your SCSI interface card. In case of problems, refer to: [Appendix A, 'Troubleshooting'](#).
 - A CD-ROM drive.
 - The amount of disk space available on your PC determines the number and size of the images you can scan. Make sure you have enough free storage space on your hard disk. You need about two times the size of the image to scan, edit and save an image. You need a minimum of 30 MB free hard disk space.

Environmental requirements

- Place the scanner on a horizontal, flat surface.
- To ensure proper ventilation, allow a minimum of 10 cm (4 inches) free space around each side of the scanner and a minimum of 15 cm (6 inches) at the rear of the scanner.
- Make sure that no vibrations or shocks occur.
- Make sure that the area is free of excessive dust.
- Avoid any contact with water.
- The scanner is designed to operate optimally when the environmental temperature is between 10 °C and 35 °C. Avoid exposure to direct sunlight and heating devices.
- The scanner is designed to operate optimally when the environmental humidity is between 10 % and 85 %. Avoid environments where humidity fluctuations might occur.
- Check whether the voltage of the power cable corresponds to the voltage in your area. If not, contact your dealer or Agfa service representative.

Precautions

For your own safety and that of your equipment, respect conscientiously the environmental requirements (see the above section) and always take the following precautions:

Caution: For the reason of safety, besides the personal maintenance mentioned in this owner's guide, don't try to remove any mechanical parts or any electronic devices. If your scanner needs servicing, our dealer and service offices are available to help you.

- Handle your DuoScan HiD with care: its glass plates are fragile. There is no warranty on breaking the glass plates and your dealer is not liable for the consequential damages.
- Frequently check that there is no overheating of the power plug and that the power plug is pushed all the way into the socket.
- Switch the machine off at the end of your working day or during power failure.
- Disconnect the power plug when you want to clean the reflective glass plate and when the scanner needs servicing.
- Do not open the scanner housing as it contains high voltage areas and sensitive components. Any corrective maintenance should be carried out by your dealer or Agfa service representative.

- Do not leave originals on the reflective glass plate or on the slide holder frame for excessive periods of time. The warmth of the scanner may cause them to deteriorate.
- Make sure that the originals are properly attached on the glass plate, otherwise you might lose them in the scanner.
- To avoid crashes, never use extension cables for SCSI cables.
- For safety reasons, never use extension cables for power cables.

Cleaning your scanner

- In order to maintain the quality of your scanned images, regularly clean both glass plates (the reflective glass plate and the universal glass frame).
- Before cleaning, switch off the power to the scanner and unplug the cable.
- Use a damp cloth and a mild detergent or alcohol to clean the surface of the glass plate.
- When you use sprays directly onto the glass plate, avoid the seams around the glass, as this may cause the liquid to penetrate and contaminate the mirrors and lenses inside the scanner. Do not use detergent on the plastic parts of your scanner.
- The cleaning of the calibration slit in the transparency holder frame is especially important. Keep this area dust- and dirt-free.

SCSI devices

DuoScan HiD is a Small Computer System Interface (SCSI) device. It communicates with your computer by using the SCSI-2 standard. The SCSI communication standard allows you to have up to seven peripheral devices connected to your computer.

Before connecting the SCSI devices you should always make sure that your computer and all SCSI devices are switched off. If either the computer or any of the devices remains on, you could damage the computer or the device.

A unique SCSI ID number is assigned to each device in the SCSI chain enabling your computer to identify the device it wants to communicate with and the priority of each device.

Caution: If two SCSI devices have the same ID number, your system will not work properly and you may damage your SCSI devices.
To avoid crashes, never use extension cables for SCSI cables.

Installation for the Apple Macintosh

This section shows you how to set up your DuoScan HiD with your Macintosh computer. You must first choose and set a SCSI ID number, then connect the scanner to your Macintosh, and finally test the connection.

[Which SCSI interface card](#)

[Choosing a SCSI ID number](#)

[Connecting the scanner](#)

[Testing the connection](#)

Which SCSI interface card

DuoScan HiD requires a SCSI interface card to work with your Macintosh. If your Macintosh does not have such a card or built-in interface, contact your dealer or Agfa service representative.

Adaptec products are recommended to use together with your DuoScan HiD.

- ❖ Note: Please check the following documentation:
 - The documentation supplied with your interface card. This will tell you how to install the card.
 - If you are using third party software, check the documentation supplied with that software for the SCSI interface cards supported.

Choosing a SCSI ID number

Before you connect your DuoScan HiD to your Macintosh, you have to find out which SCSI ID numbers are already assigned and which numbers are free. To do this, you can use the utility 'SCSI ID Checker'. You will find this utility in the FotoLook folder after you installed the software.

1. Copy the SCSI ID Checker to your Macintosh computer if not already done.
2. Open the SCSI ID Checker.

A dialog box appears with a list of the SCSI ID numbers that are free in your Macintosh computer.

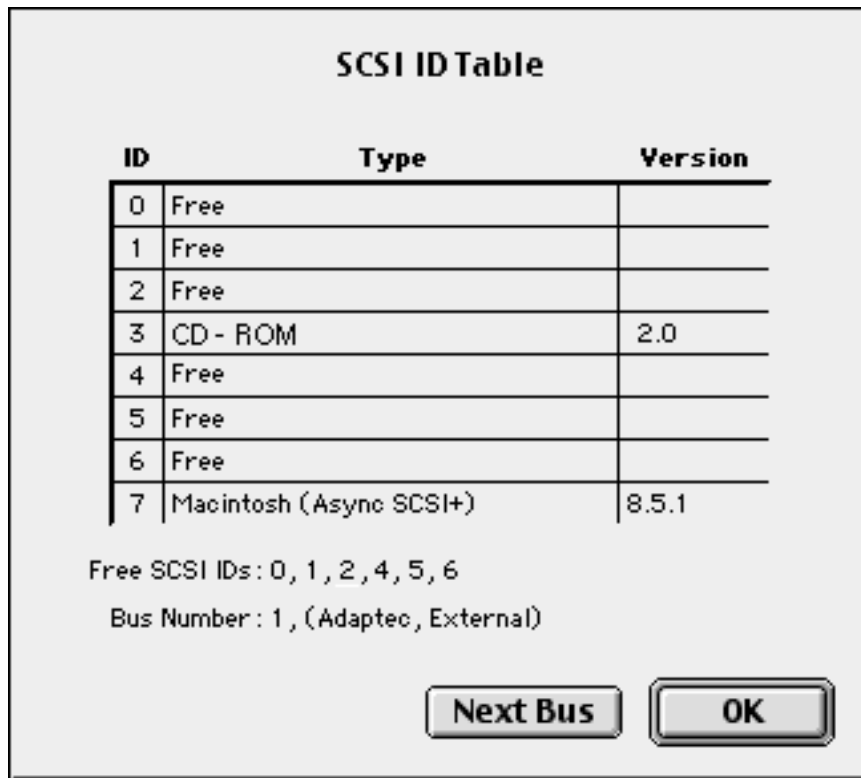

Your Macintosh always occupies ID 7, its internal hard disk usually occupies ID 0 or ID 1 and CD ROM usually occupies ID 3. If your Macintosh is equipped with 2 SCSI-busses, the button Next Bus allows you to switch busses.

3. Check if SCSI ID number 2 is free.
Your DuoScan HiD is preset to ID 2.
4. If SCSI ID number 2 is free, go to instruction 5.
If SCSI ID number 2 is already assigned, you need to set the scanner to a free SCSI ID number.
 - ❑ Make sure your scanner is switched off and is disconnected from your computer.
 - ❑ Decide on an unassigned SCSI ID number.
 - ❑ Use the SCSI ID switch (see figure) at the rear of the scanner to set the desired SCSI ID.
 - ❑ Push above the SCSI ID number to decrease the number, push underneath the SCSI ID number to increase the number.

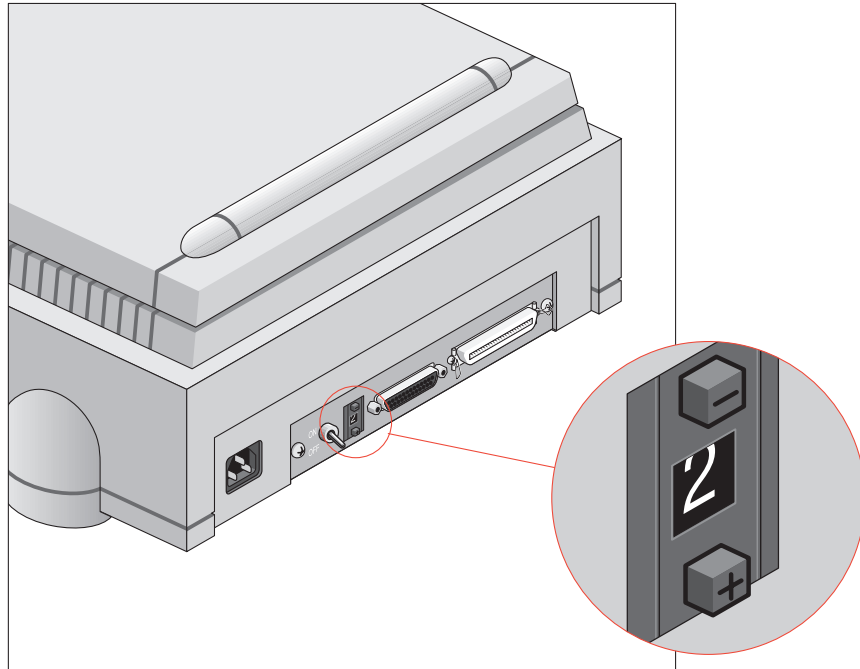

5. Click OK to close the SCSI ID Checker.

Connecting the scanner

Caution: Install the scanner software, as described in the Getting Started, before connecting the scanner to your computer.

Before you connect the scanner to your Macintosh, make sure that your scanner as well as your Macintosh and everything connected to it are switched off.

Caution: For safety reasons, never use extension cables for power cables. Always make sure there are no more than two terminators in your SCSI chain, one at the beginning and one at the end. Some SCSI devices have built-in terminators and must therefore be placed at the beginning or end of your SCSI chain. Please check the documentation of each of your SCSI devices if you're not sure whether the device has a built-in terminator.

Because your DuoScan HiD has a built-in terminator you do not need to use an external terminator. To activate the built-in terminator switch the SCSI terminator on.

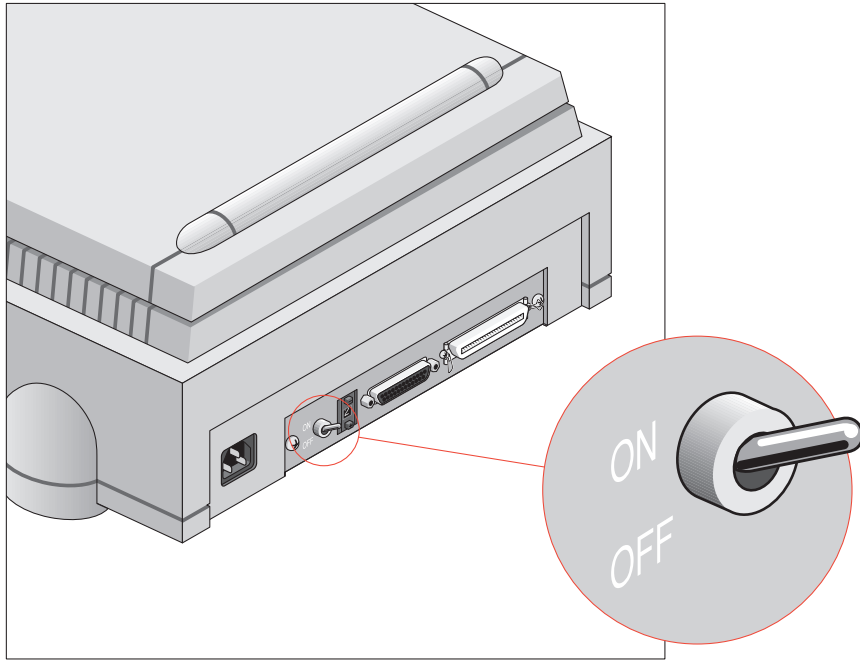

If your DuoScan HiD is the only SCSI device to be connected to your Apple Macintosh:

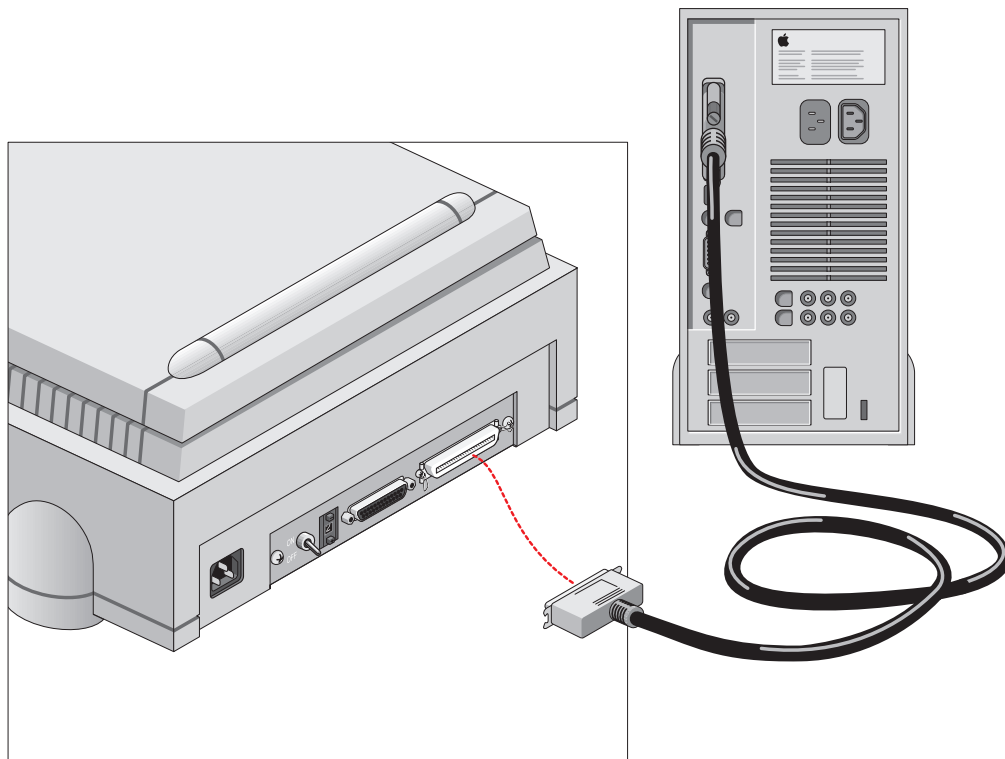

1. Connect the smaller 25-pin end of the SCSI cable to the connector of your Apple Macintosh.

2. Connect the larger 50-pin end of the SCSI cable to the free side of the terminator.
3. Snap the diamond shaped wire clips into the clip brackets to secure the connection.
4. Switch on the internal terminator.

If your DuoScan HiD will be connected to your Apple Macintosh together with other SCSI devices:

If you install the scanner at the end of your SCSI chain:

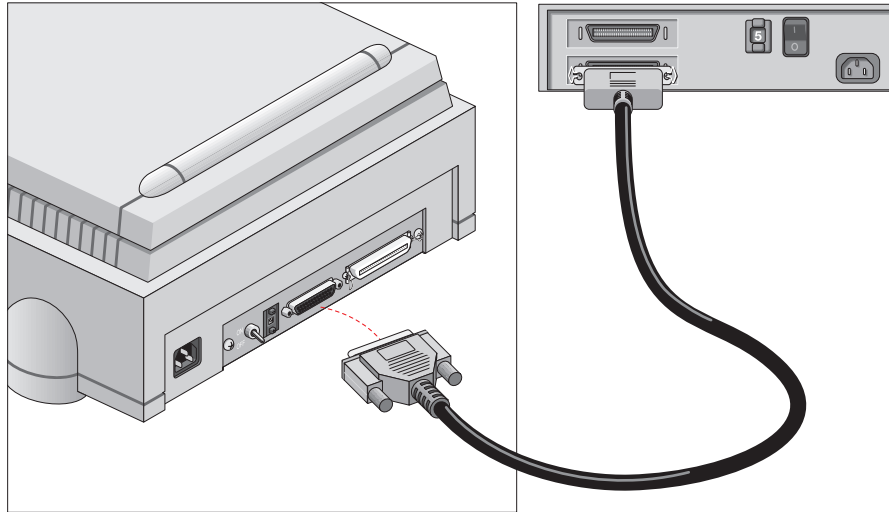

1. Remove the terminator from the last device in the SCSI chain.
2. Connect the 50-pin end of the SCSI cable to the connector that has become available on this device.
3. Connect the 25-pin end of the SCSI cable to the free connector of the scanner.
4. Snap the diamond shaped wire clips into the clip brackets to secure the connection.
5. Switch the internal terminator on.

If you install the scanner between two other SCSI devices:

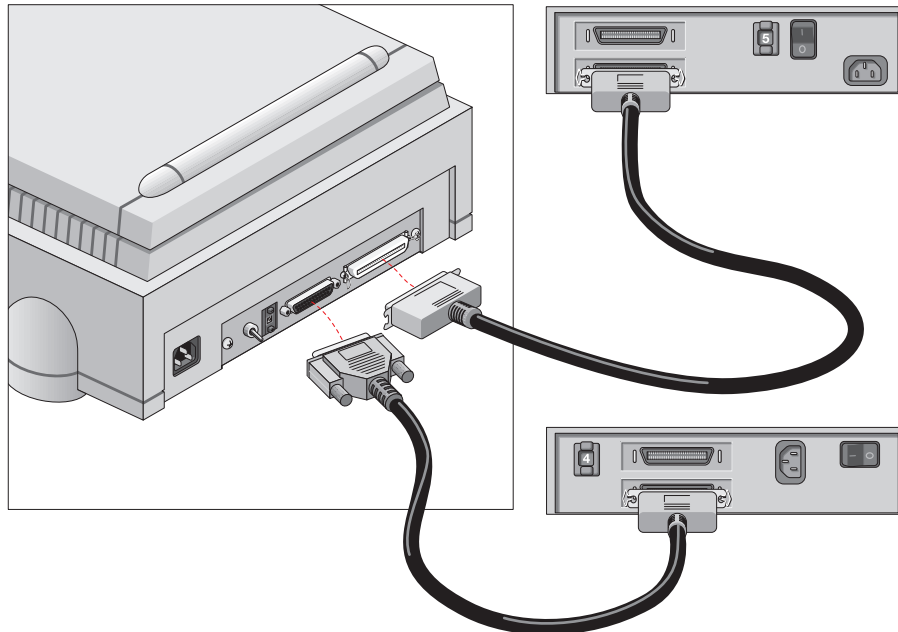

- ❖ **Note:** Make sure the internal terminator of the scanner is switched off.
- 1. Disconnect your SCSI cable from one of these two SCSI devices.
- 2. Connect the free end of this SCSI cable to the scanner.
- 3. Connect the 50-pin end of the SCSI cable (the one supplied with your scanner) to the other adjacent SCSI device.
- 4. Connect the 25-pin end of the SCSI cable (the one supplied with your scanner) to the scanner.
- 5. Snap the diamond shaped wire clips into the clip brackets to secure the connection.

Testing the connection

You are now ready to perform a test to check if the scanner is correctly connected to your Macintosh.

Caution: Check if the scanner is properly unlocked.

1. Connect the power cable to the scanner.
Make sure that you are using the correct power cable for the voltage in your area.
2. Check if the SCSI cable is properly connected.
3. Switch the scanner on.
The scanner performs a self-test: the power indicator light switches on and the two other indicator lights start blinking. After the self-test all the scanner's indicator lights switch on.
4. Switch on any other SCSI devices you may have attached, and wait for them to start up.
5. Switch on your Macintosh.
As it starts up, your Macintosh performs a series of tests to verify the correct system configuration.
6. Open the SCSI ID checker.
7. Verify whether the Macintosh sees the scanner at its proper SCSI address.
In case of problems, refer to [Appendix A, 'Troubleshooting'](#).
8. Close the SCSI ID checker.

Installation for the PC

This section shows you how to set up your DuoScan HiD with your PC. You can find information on which SCSI interface card to use, instructions for connecting the scanner to your PC and instructions for testing the connection.

[Which SCSI interface card](#)

[Choosing a SCSI ID number](#)

[Connecting the scanner](#)

[Testing the connection](#)

Which SCSI interface card

DuoScan HiD requires a SCSI interface card to work with your PC or compatible computer. If your PC does not have such a card or built-in interface, contact your dealer or Agfa service representative.

Adaptec products are recommended to use together with your DuoScan HiD.

- ❖ Note: Please check the following documentation:
 - The Read Me file on the PC scanner driver software disk for up-to-date information.
 - The documentation supplied with your interface card. This will tell you how to install the card.
 - If you are using third party software, check the documentation supplied with that software for the SCSI interface cards supported.

Choosing a SCSI ID number

Before you connect your DuoScan HiD to your PC, you have to find out which SCSI ID numbers are already assigned and which numbers are free. To do this, you can use a Windows utility that is usually bundled with your SCSI interface card.

1. Open the utility.
A list of the free SCSI ID numbers appears.
Your PC always occupies ID 7. If your PC is equipped with 2 SCSI-busses, the button Next Bus allows you to switch busses.
2. Check if SCSI ID number 2 is free.
Your DuoScan HiD is preset to ID 2.

3. If SCSI ID number 2 is free, go to instruction 4.
If SCSI ID number 2 is already assigned, you need to set the scanner to a free SCSI ID number.
 - ❑ Make sure your scanner is switched off and is disconnected from your computer.
 - ❑ Decide on an unassigned SCSI ID number.
 - ❑ Use the SCSI ID switch at the rear of the scanner to set the desired SCSI ID.

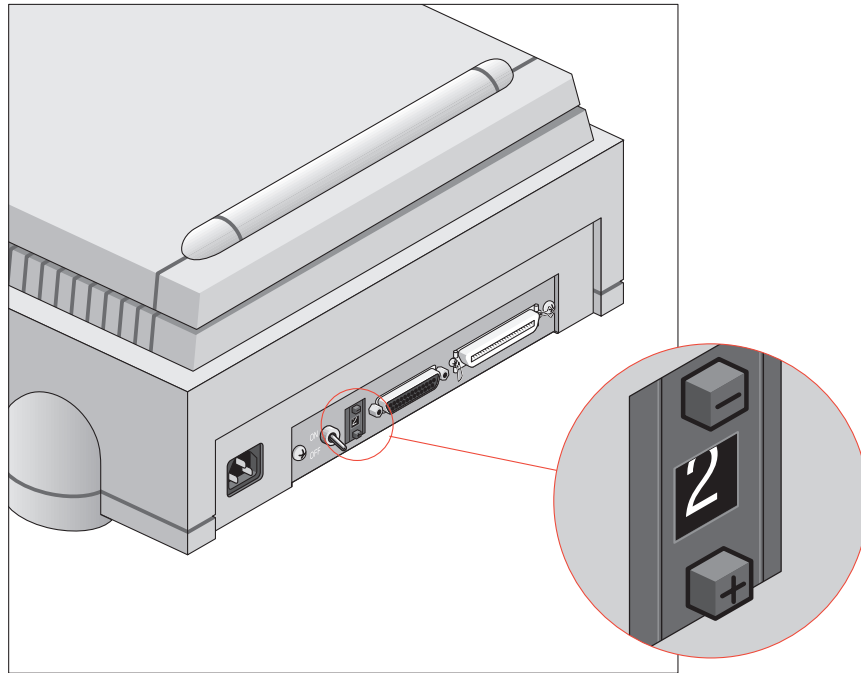

- ❑ Push above the SCSI ID number to decrease the number, push underneath the SCSI ID number to increase the number.
4. Close the utility.

Connecting the scanner

Caution: Install the scanner software, as described in the Getting Started, before connecting the scanner to your computer.

Before you connect the scanner to your PC, make sure that your scanner as well as your PC and everything connected to it are switched off.

A SCSI cable is supplied with your scanner.

Caution: For safety reasons, never use extension cables for power cables. Always make sure there are no more than two terminators in your SCSI chain, one at the beginning and one at the end. Some SCSI devices have built-in terminators and must therefore be placed at the beginning or end of your SCSI chain. Please check the documentation of each of your SCSI devices if you're not sure whether the device has a built-in terminator.

Because your HiD DuoScan has a built-in terminator you do not need to use an external terminator. To activate the built-in terminator switch the SCSI terminator on.

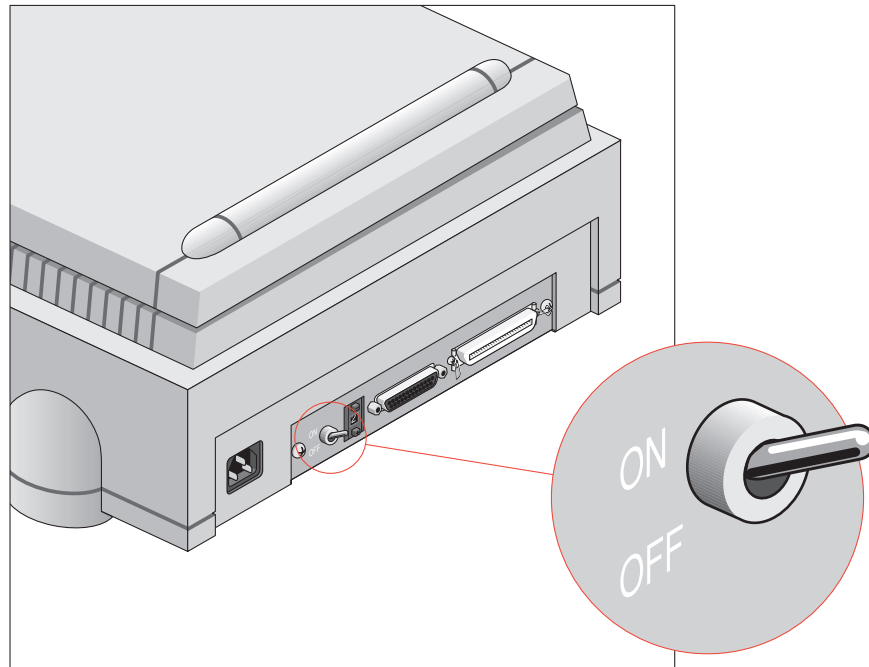

Caution: Never try to connect the scanner to the serial or parallel port of your PC: you might seriously damage your equipment.

- If your PC has a high density connector, you might need to buy a special cable from your dealer.
- If your PC has a 25-pin connector, follow the instructions of ['Connecting the scanner'](#).

If your PC has a 50-pin connector and your DuoScan HiD is the only SCSI device to be connected to your PC.

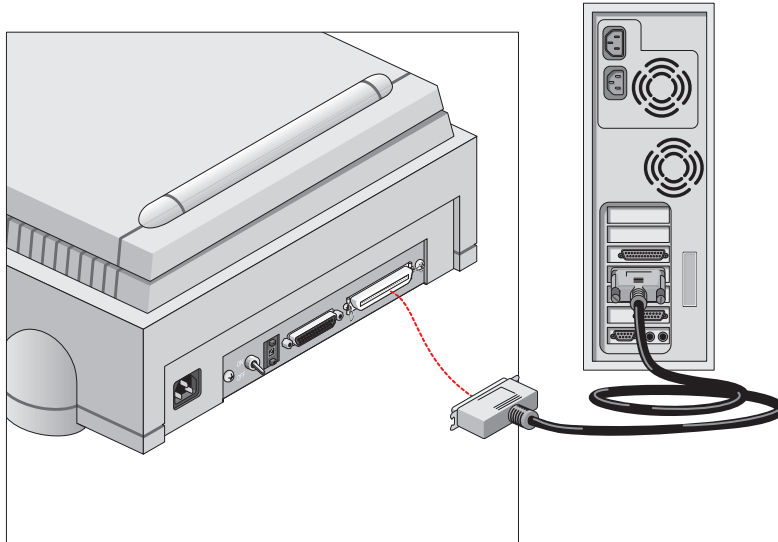

1. Set the scanner to a free SCSI ID number between 1 and 6.
For more information, see [‘Choosing a SCSI ID number’](#) earlier in this chapter.
2. Connect the larger 50-pin end of the SCSI cable to the connector at the rear of your PC.
Use the SCSI cable supplied with the scanner.
3. Connect the smaller 25-pin end of the SCSI cable to the free connector of the scanner.
If your PC has a 50-pin connector and your DuoScan HiD will be connected to your PC together with other SCSI devices.
4. Snap the diamond shaped wire clips into the clip brackets to secure the connection.
5. Switch the internal terminator on.

If you install the scanner at the end of your SCSI chain:

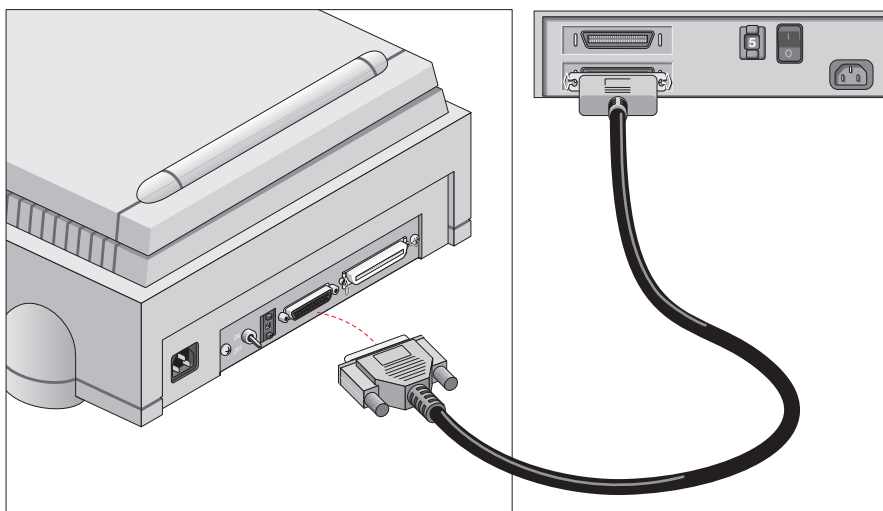

If you install the scanner at the end of your SCSI chain:

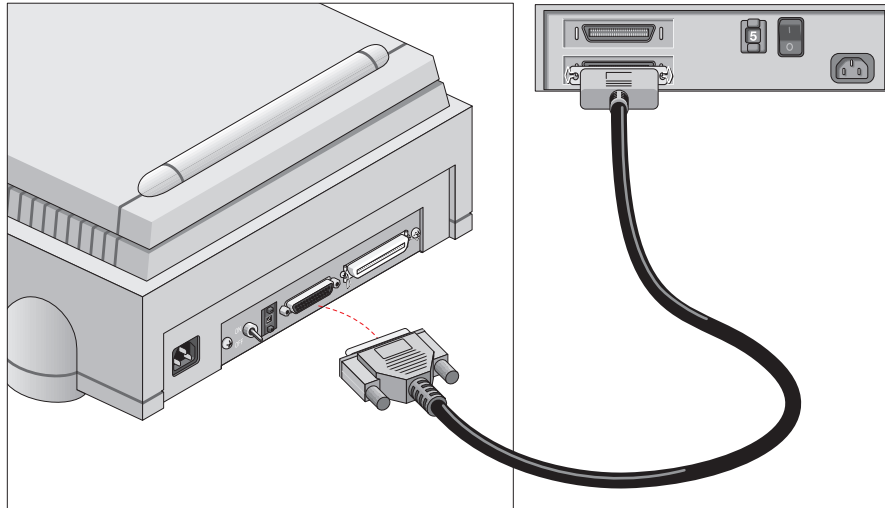

1. Set the scanner to an unused SCSI ID number between 1 and 6.
For more information, see '[Choosing a SCSI ID number](#)' earlier in this chapter.
2. Connect the 50-pin end of the SCSI cable to the connector at the rear of your device.
Use the cable supplied with the scanner.
3. Switch the internal terminator on.
4. Snap the diamond shaped wire clips into the clip brackets to secure the connection.
5. Connect the 25-pin end of the SCSI cable to the scanner.

If you install the scanner between two other devices:

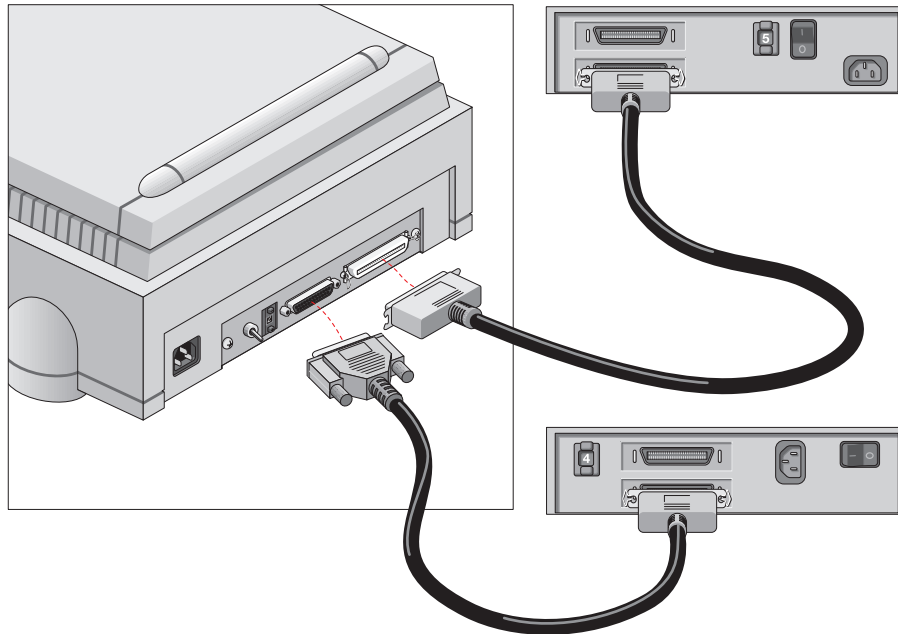

- ❖ Note: Make sure the internal terminator of the scanner is switched off.
- 1. Disconnect the two devices between which you want to install the scanner.
- 2. Set the scanner to an unused SCSI ID number between 1 and 6.
For more information, see [‘Choosing a SCSI ID number’](#) earlier in this chapter.
- 3. Connect the 50-pin end of the SCSI cable to the connector at the rear of the adjacent device.
Use the cable supplied with the scanner.
- 4. Connect the 25-pin end of the cable to the scanner's 25-pin connector.
- 5. Connect the scanner to the next device in the SCSI chain.
- 6. Make sure that the last device in the chain is terminated.

Testing the connection

You are now ready to perform a test to check if the scanner is properly connected to your PC.

Caution: Check if the scanner is properly unlocked.

1. Connect the power cable to the scanner.
Make sure that you are using the correct power cable for the voltage in your area.
2. Check if the SCSI cable is properly connected.
3. Switch the scanner on.
The scanner performs a self-test: the power indicator light (green) switches on and the ready indicator lights (yellow) start blinking. After the self-test the scanner's power indicator light switches on.
4. Switch on any other SCSI devices you may have attached, and wait for them to start up.
5. Switch on your PC.
6. Check if the scanner is present:
For Windows 95 / 98:
 1. Right-click My Computer.
 2. Select properties.
 3. Select the Device Manager tab.
'Agfa Scanners' (for Windows 95) or
Expand 'Imaging Device' (for Windows 98).
The name of your scanner should be present.
For Windows NT 4.0:
 1. In the Startmenu select: Start\Settings\Control Panel\SCSI adapter.
 2. Expand the name of your SCSI card.
The name of your scanner should be present.

Appendix A — Troubleshooting

This appendix explains some common problems you may come across when starting up or using your DuoScan HiD.

The power indicator fails to light up.

- Verify the power connection to the scanner.
- Check if the power switch is turned on.
- If you have confirmed that there is power to the scanner it is likely that the scanner fuse needs to be replaced. Contact your dealer.

The power indicator lights up but nothing happens.

- Contact your dealer or Agfa service representative.

The scanner makes a loud knocking noise and nothing moves under the glass plate.

- The scanner was not properly unlocked. Immediately switch the scanner off and unlock properly, or call your service representative.

The ready indicator light (yellow) on the scanner's operating panel remains blinking or goes off after the power-up sequence (= about half a minute).

- A malfunction has been detected by the scanner.
- Check if you have unlocked the scanner. If this can not be the problem please contact your dealer or Agfa service representative.

The power indicator fails to light up.

- Verify the power connection to the scanner.
- Check if the power switch is turned on.
- If you have confirmed that there is power to the scanner it is likely that the scanner fuse needs to be replaced. Contact your dealer.

The workstation does not start up. If your workstation is an Apple Macintosh a little floppy disk with a question mark appears on your screen.

Your workstation cannot find its hard disk due to a conflict with the SCSI ID numbers of the devices you have attached.

- Disconnect all SCSI devices (except the start-up disk) and connect them one by one, beginning with the scanner, to identify the device that causes the problem (switch all devices off before breaking or making connections).

The scanner software cannot find the scanner.

After opening the Scan dialog box, a message appears telling that no scanner is connected, although the scanner is connected.

- Check the Installation procedure, to see if you followed the instructions. Pay special attention to the setting of the SCSI ID number: check the SCSI ID Checker.
- Maybe you did not wait long enough for all SCSI devices to start up, before you switched your workstation on. Therefore, try restarting your workstation. If this doesn't help,
- Disconnect all SCSI devices and connect them one by one, beginning with the scanner, to identify the device that causes the problem.

The scanner reports errors during scanning (Apple Macintosh).

- Check the status of the SCSI terminator. If this is not the problem, please contact your dealer or Agfa service representative.

When starting up, the scanner makes a beeping noise and all the lights are blinking.

- This indicates a SCSI cabling problem. Be sure to immediately shut down all machines in the chain and then solve the problem. (Missing terminator? Bad cable? Internally terminated component in chain?)

Appendix B — Technical Information

This appendix provides some technical information about your DuoScan HiD. Technical specifications are subject to change without notice.

Scanner type:	Flatbed legal or A4 size color CCD scanner
CCD:	8000 elements, color type
Optical resolution:	2000 dpi vertical x 1000 dpi horizontal
Output resolution:	25 - 4000 ppi
A/D Conversion:	42 bit (14 bit/color)
Output pixel depth:	1 bit output for line-art (black and white) 8 or 14 bit output for gray 24 or 48 bit output for color
Density range:	3.2 D
Max. density detected:	3.7 D
Scanning speed:	7-20 ms/line
Original sizes:	A4 or Legal
Maximum scan area:	Maximum reflection: 8 x 14 inch (203 x 355 mm) Maximum transmission: 8 x 10 inch (203 x 254 mm transparency)
Memory:	1 Mb RAM
Reflection scanner lamp:	2 x cold cathode 6000 hr lifetime
Transparency lamp:	Cold cathode 6000 hr lifetime
Warm up time:	approximately 35 seconds 180 seconds to reach final image quality

Power supply:	100 V to 240 V, 47 - 63 Hz
Power consumption:	40 W
Dimensions:	400 mm (16 inch) x 182 mm (7 inch) x 613 mm (24 inch) (W x H x L)
Weight:	13,5 kg
Acoustic noise:	max. 55 dB in worst condition
Interface:	SCSI-2 interface Maximum throughput 4 MB / sec
Environment:	Operating temperature: 10 °C to 35 °C (50 °F to 95 °F) Relative humidity: 10 % to 85 %

Appendix C — Regulation Compliance

[Safety regulations](#)

[Electromagnetic interference](#)

Safety regulations

DuoScan HiD has been designed to comply with:

- VDE 805
- IEC 950, EN 60950 (GS approved)
- UL 1950-D3
- CSA c22.2 No. 950-M89

DuoScan HiD also complies with CE regulations and carries the CE mark.

UL Safety Statement

Instructions for power supply cord selection:

Use a UL listed, Type SVT or SJT cord, three conductor, rated 10 A 125 V, not exceeding 15ft in length.

FTZ: Bescheinigung des Herstellers/Importeurs

Hiermit wird bescheinigt dass der Image Scanner in Übereinstimmung mit den Bestimmungen der vgf 1046/1984 funk-entstört ist.

Der Deutschen Bundespost wurde das Inverkehrbringen dieses Gerätes angezeigt und Berechtigung zur Überprüfung der Serie auf Einhaltung der Bestimmungen eingeräumt.

TÜV: Wichtige Sicherheitshinweise

1. Bitte Lesen Sie sich diese Hinweise sorgfältig durch.
2. Um eine Beschädigung des Gerätes zu vermeiden sollten Sie nur Zuberhörteile verwenden, die vom Hersteller zugelassen sind.
3. Das Gerät ist vor Feuchtigkeit zu schützen.
4. Bei der Aufstellung des Gerätes ist auf sicheren Stand zu achten. Ein Kippen oder Fallen könnte Verletzungen hervorrufen. Verwenden Sie nur sichere Standorte und beachten Sie die Aufstellhinweise des Herstellers.

6. Die Netzanschlußsteckdose muß aus Gründen der elektrischen Sicherheit einen Schutzleiterkontakt haben.
7. Durch die Lüftungsöffnungen dürfen niemals Gegenstände oder Flüssigkeiten in das Gerät gelangen. Dies könnte einen Brand bzw. elektrischen Schlag auslösen.
8. Öffnen Sie niemals das Gerät. Das Gerät darf aus Gründen der elektrischen Sicherheit nur von autorisiertem Servicepersonal geöffnet werden.
9. Die Steckdose sollte nahe dem Gerät und leicht zugänglich sein.

Electromagnetic interference

DuoScan HiD is designed to comply with:

- VDE 0871, class B
- VDE 0875, level N
- FCC 20718, part 15, subpart B, class B

Federal Communications Commission Radio Frequency Interference Statement.

❖ Note: This equipment has been tested and found to comply with the limits for a Class B digital device, pursuant to Part 15 of the FCC Rules. These limits are designed to provide reasonable protection against harmful interference when the equipment is operated in a residential installation. This equipment generates, uses, and can radiate radio frequency energy and if not installed and used in accordance with the instruction manual may cause harmful interference to radio communications. However, there is no guarantee that interference will not occur in a particular installation. If this equipment does cause harmful interference to radio or television reception, which can be determined by turning the equipment off and on, the user is encouraged to try to correct the interference by one or more of the following measures:

- Reorient or relocate the receiving antenna.
- Increase the separation between the equipment and receiver.
- Connect the equipment into an outlet on a circuit different from that to which the receiver is connected.
- Consult the dealer or an experienced radio TV technician for help.

Notice:

1. The changes or modifications not expressly approved by the party responsible for compliance could void the user's authority to operate the equipment.
2. Shielded interface cables and AC power cord, if any, must be used in order to comply with the emission limits.

Canadian department of Communications

This digital apparatus does not exceed the Class B limits for radio noise emissions from digital apparatus set out in the Radio Interference Regulations of the Canadian Department of Communications.

Le présent appareil numérique n'émet pas de bruits radioélectriques dépassant les limites applicables aux appareils numériques (de la classe B) prescrites dans le Règlement sur le brouillage radioélectrique édicté par le ministère des Communications du Canada.